

"EUROMODEL" INDEXED CLAMPING LEVER WITH PLASTIC PUSH BUTTON AND WITH THREADED STUD

A583



Material:

Special high resistance glass fiber reinforced technopolymer. Oils and greases resistant.

Surface:

Satin.

Lever body and insert colour:

Black (RAL 9011).

Main insert:

Zinc plated steel threaded stud.
(Thread tolerance 6g).

Push Button:

Push button in black polyamide (RAL 9011).

Spring:

Stainless steel spring (AISI 302).

Alternative colours for lever body and button:

Orange	(RAL 2004 cod. 02)
Blue	(RAL 5015 cod. 07)
Yellow	(RAL 1021 cod. 10)
Red	(RAL 3000 cod. 16)
Green	(RAL 6024 cod. 17)
Grey	(RAL 7035 cod. 13)
Black	(RAL 9011 cod. 01)



SPECIAL REQUESTS:

- It's possible to supply the inserts with different lengths, on request and for quantities.
- It's possible to supply the inserts with different materials, on request and for quantities.
- It's possible to supply the lever body and button with colours as shown in the table at page A-31 on request and for quantities.

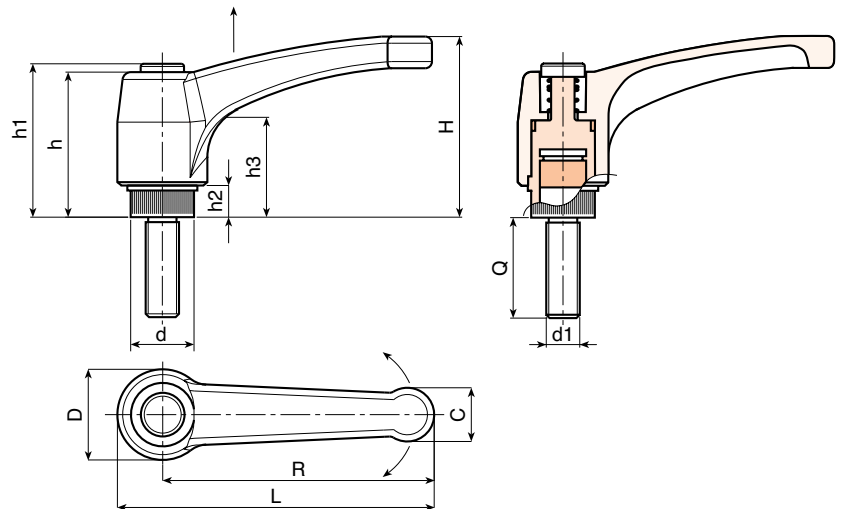

Art.	L	R	H	D	d	c	h	h1	h2	h3	LM	d1	6g	Q	g
A583043.TM04X..01	51	43	33	17	11,5	9	29	32	6	18	75	M04		10-16-20-25-30-40	9-10-10-11-11-12
A583043.TM05X..01	51	43	33	17	11,5	9	29	32	6	18	75	M05		10-16-20-25-30-40	12-13-13-14-15-16
A583043.TM06X..01	51	43	33	17	11,5	9	29	32	6	18	75	M06		10-16-20-25-30-40-50	14-15-15,5-16-16,5-18-19,5
A583052.TM06X..01	63	52	41	22	15	12	36	40	8	23	90	M06		16-20-25-30-35-40-50	22-23-24-25-26-27-28
A583052.TM08X..01	63	52	41	22	15	12	36	40	8	23	90	M08		16-20-25-30 35-40-45-50	24-25-27-28,5 30-31,5-33-34,5
A583052.TM10X..01	63	52	41	22	15	12	36	40	8	23	90	M10		20-25-30-35-40-50	31-33,5-36-38,5-41-46
A583065.TM06X..01	76	65	43	23	15	13	36	40	8	24	90	M06		16-20-25-30-35-40-45-50	26-27-27-28-28-29-30
A583065.TM08X..01	76	65	43	23	15	13	36	40	8	24	90	M08		16-20-25-30 35-40-45-50	31,5-33-34,5-36-37,5 39-41-42,5-44
A583065.TM10X..01	76	65	43	23	15	13	36	40	8	24	90	M10		20-25-30-35-40-45-50	37-39,5-42-44,5-47-49,5-52
A583080.TM08X..01	93	80	54	27	19	15,5	44	48	8,5	29	90	M08		20-25-30-35-40-50	47-49-50,5-52-54-57
A583080.TM10X..01	93	80	54	27	19	15,5	44	48	8,5	29	90	M10		20-25-30-35-40-45-50	54-56,5-59-61,5-64 66,5-69-74-79
A583080.TM12X..01	93	80	54	27	19	15,5	44	48	8,5	29	90	M12		20-25-30-35-40 50-60-70	65-69-72-75-79-83 86-93-100-107
A583094.TM08X..01	109	94	56	30	19	18	45	49	9	30	90	M08		20-25-30-35-40-50	55-57-58-60-62-65
A583094.TM10X..01	109	94	56	30	19	18	45	49	9	30	90	M10		20-25-30-35-40-50-60-70	62-67-69-72 75-77-82-87
A583094.TM12X..01	109	94	56	30	19	18	45	49	9	30	90	M12		20-25-30-35-40 50-60-70	73-80-83-87-91-94 101-108-115
A583108.TM12X..01	125	108	64	34	24	21	51	55	10	35	100	M12		20-30-40-50-60-70	101-108-115-122-129-136
A583108.TM14X..01	125	108	64	34	24	21	51	55	10	35	100	M14		30-40-50-60	114-121-128-134
A583108.TM16X..01	125	108	64	34	24	21	51	55	10	35	100	M16		40-50-60	139-151-163

Enter the stud length choice in the two .. of the article code. Lengths by request with 50 pieces minimum quantity.

LM = Maximum mouldable length.

Availability of stock in %

(☺) 90% (☺) 40% (☹) 5% (☹)

BOTECO® - © All right reserved - www.boteco.it
Any unauthorized reproduction is strictly forbidden



A - INDEXED AND FIXED LEVERS