

CRANK HANDLE WITH SMOOTH INSERT AND REVOLVING AND FOLDING HANDLE

E217



Material: Reinforced polyamide. Oils and greases resistant.

Surface: Satin.

Colour: Black (RAL 9011).

Central Cap: Grey polyamide RAL 7035 (cod. 13).

Alternative Cap Colour:

- Orange (RAL 2004 cod. 02)
- Red (RAL 3000 cod. 16)
- Blue (RAL 5015 cod. 07)
- Green (RAL 6024 cod. 17)
- Yellow (RAL 1021 cod. 10)
- Black (RAL 9011 cod. 01)

Main Insert:

Zinc plated steel insert with smooth through-hole (H11 tolerance).

Side Insert: Brass right through threaded bush.

Side Handle: Revolving handle and folding Art. M136.



SPECIAL REQUESTS:

- It is possible to supply the inserts with d1 diameter by customer design, on request and for quantities.
- It is possible to supply the inserts in different materials, on request and for quantities.
- It is possible to supply the inserts in different treatment-finishes, on request and for quantities.
- It is possible to supply arm and handle with colours as shown in the table at pag. 19, on request and for quantities.

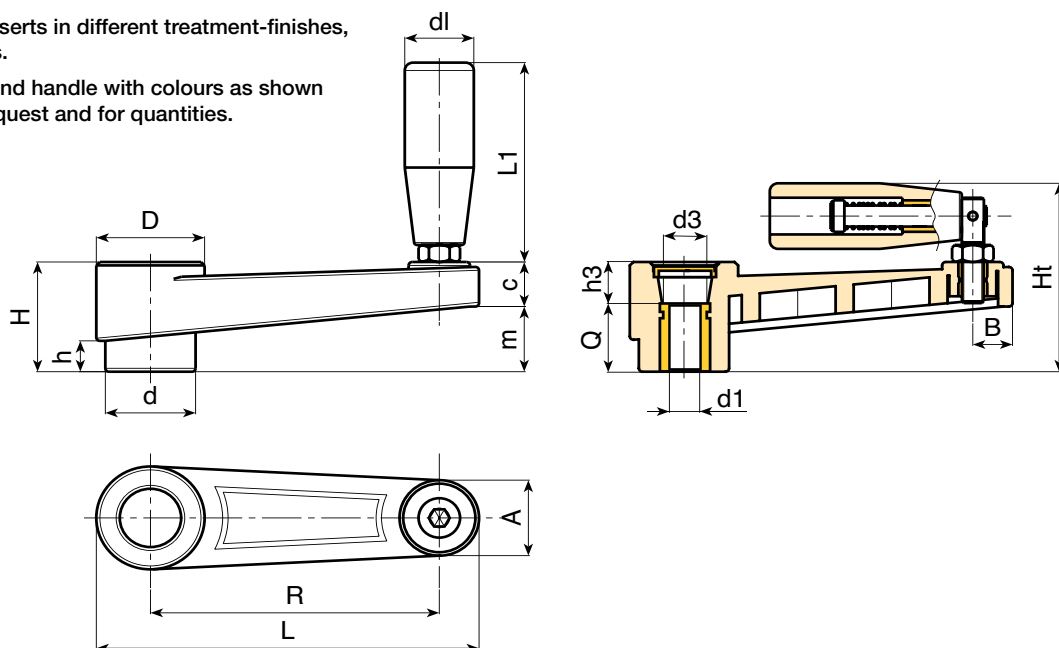

Art.	L	R	H	Ht	D	d	m	c	A	B	h	d3	h3	dm	d1 H11	Q	dl	L1	g
E217065.TD0501	88	65	30	54	27	22	17	13	18	9,5	8	14	10	12	D05	20	20	54	105
E217065.TD1001	88	65	30	54	27	22	17	13	18	9,5	8	14	10	12	D10	20	20	54	100
E217080.TD0501	106	80	33	57	30	26	19	13	21,5	11	9	18	9	14	D05	24	20	54	115
E217080.TD1001	106	80	33	57	30	26	19	13	21,5	11	9	18	9	14	D10	24	20	54	110
E217110.TD0501	138	110	39	67,5	33	29	25	14	22	12	11	18	11	14	D05	28	25	75	156
E217110.TD1201	138	110	39	67,5	33	29	25	14	22	12	11	18	11	14	D12	28	25	75	156
E217140.TD0501	174	140	49	82	41	35	33	16	25,5	13,5	15	23**	19**	20	D05	30	26	89	300
E217140.TD1401	174	140	49	82	41	35	33	16	25,5	13,5	15	23**	19**	20	D14	30	26	89	240
E217185.TD0501	220	185	55	88	45	40	40	16,5	26,5	14	16,5	28**	21**	22	D05	34	26	97	450
E217185.TD1601	220	185	55	88	45	40	40	16,5	26,5	14	16,5	28**	21**	22	D16	34	26	97	430

dm = It's possible to increase the hole, by boring, until Dm (enlarge).

**= not definitive measures

Presumable presence in the stock in %

(🏭) 90% (😊) 40% (☹️) 5% (😞)

BOTECO® - © All right reserved - www.boteco.it

Any unauthorized reproduction is strictly forbidden



BOTECO

**E - FIXED AND INDEXED
CRANK HANDLES**