

F288-F288PIN



PA6
+GF

UL94
HB



SOLID CROSS HANDWHEEL WITH STEEL/STAINLESS STEEL HUB AND RIGHT THROUGH THREADED HOLE

Material:

Reinforced polyamide.
Oils and greases resistant.

Surface:

Satin.

Colour:

Black (RAL 9011).

Inserts:

F288 Zinc plated steel insert with female right through threaded hole (tolerance 6H).

F288 PIN: Stainless steel (AISI 303) insert with female right through threaded hole (tolerance 6H).



SPECIAL REQUESTS:

- It's possible to supply the inserts with d1 bore by customer design, on request and for quantities.
- It is possible to supply colours as shown in the table on page F-35, on request and for quantities.

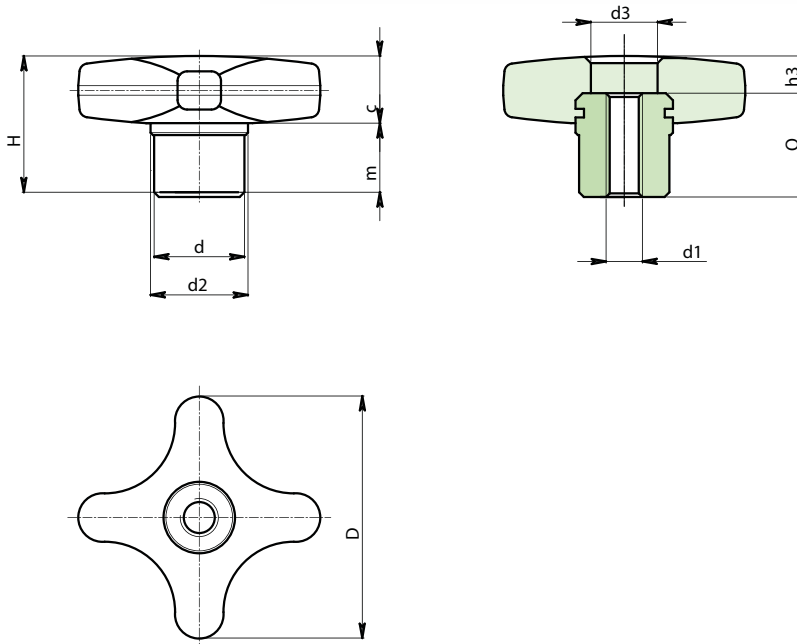

Version F288: Zinc plated steel

😊	Art.	D	d	d2	d3	H	h3	m	c	d1 6H	Q	⚖️ g
😊	F28832.TM0601P	32	13	15	8	22	4	11	11	M06	18	21
😊	F28840.TM0801P	40	14	16	11	24	6	12	12	M08	18	28
😊	F28850.TM1001P	50	18	20	14	29	7	15	14	M10	22	49
😊	F28860.TM1201P	60	20	24	16	34	6	18	16	M12	28	81

Version F288 PIN: Stainless steel AISI 303

😊	Art.	D	d	d2	d3	H	h3	m	c	d1 6H	Q	⚖️ g
😊	F28832.TM0601PIN	32	13	15	8	22	4	11	11	M06	18	21
😊	F28840.TM0801PIN	40	14	16	11	24	6	12	12	M08	18	28
😊	F28850.TM1001PIN	50	18	20	14	29	7	15	14	M10	22	49
😊	F28860.TM1201PIN	60	20	24	16	34	6	18	16	M12	28	81

INOX

**F - SOLID
LOCKING KNOBS**

ver. FUK.15-0413



BOTECA

F - 28

Presumable presence in the stock in %

(😊) 90% (😊) 40% (😐) 5% (😞)

www.boteco.it - © All right reserved - BOTECA®
Any unauthorized reproduction is strictly forbidden