

I103



PA6
+GF

UL94
HB



BALL KNOB WITH PLASTIC THREADED HOLE

Material:

Reinforced polyamide.
Oils and greases resistant.

Surface:

Satin.

Colour:

Black (RAL 9011).

Hole:

Female threaded blind hole obtained by moulding the plastic. (tolerance in not applicable).

SPECIAL REQUEST:

- It is possible to supply colours as shown in the table at pag. I-23, on request and for quantities.
- (*) ATTENTION: Reduced colour range.

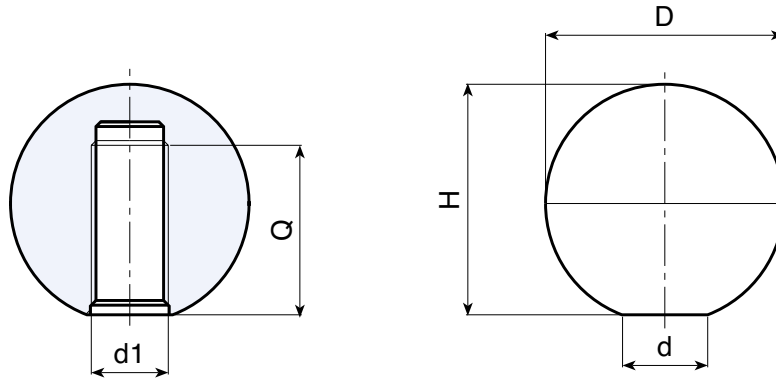

	art.	D	H	d	d1	Q	g
	I10315.TM0401	15	14	9	M04	10	2
	I10315.TM0501	15	14	9	M05	10	2
	I10320.TM0401	20	19	10	M04	14	6
	I10320.TM0501	20	19	10	M05	14	6
	I10320.TM0601	20	19	10	M06	14	6
	I10320.TM0801	20	19	10	M08	14	6
	I10325.TM0501	25	23	14	M05	18	10
	I10325.TM0601	25	23	14	M06	18	10
	I10325.TM0801	25	23	14	M08	18	10
	I10325.TM1001	25	23	14	M10	18	8
	I10330.TM0501	30	29	14	M05	22	18
	I10330.TM0601	30	29	14	M06	22	18
	I10330.TM0801	30	29	14	M08	22	16
	I10330.TM1001	30	29	14	M10	22	16
	I10330.TM1201	30	29	14	M12	22	14
	I10335.TM0601	35	33	16	(*) M06	25	28
	I10335.TM0801	35	33	16	(*) M08	25	26
	I10335.TM1001	35	33	16	(*) M10	25	26
	I10335.TM1201	35	33	16	(*) M12	25	26
	I10340.TM0801	40	39	16	(*) M08	25	42
	I10340.TM1001	40	39	16	(*) M10	25	36
	I10340.TM1201	40	39	16	(*) M12	25	36
	I10340.TM1401	40	39	16	(*) M14	25	34
	I10345.TM0801	45	44	18	(*) M08	25	60
	I10345.TM1001	45	44	18	(*) M10	25	58
	I10345.TM1201	45	44	18	(*) M12	25	58
	I10345.TM1401	45	44	18	(*) M14	25	56
	I10350.TM1001	50	49	18	(*) M10	25	80
	I10350.TM1201	50	49	18	(*) M12	25	78
	I10350.TM1401	50	49	18	(*) M14	25	76

