

# L749



PA6  
+GF

UL94  
HB



## 28MM. WINGNUT WITH THREADED STUD

### Material:

Reinforced polyamide.  
Oils and greases resistant.

### Surface:

Satin.

### Colour:

Black (RAL 9011).

### Main Insert:

Zinc plated steel threaded stud (tolerance 6g).

### SPECIAL REQUESTS:

- It is possible to supply inserts in different lengths or by special design, on request and for quantities.
- It is possible to supply inserts in different materials, on request and for quantities.
- It is possible to supply colours as shown in the table on page L-27, on request and for quantities.

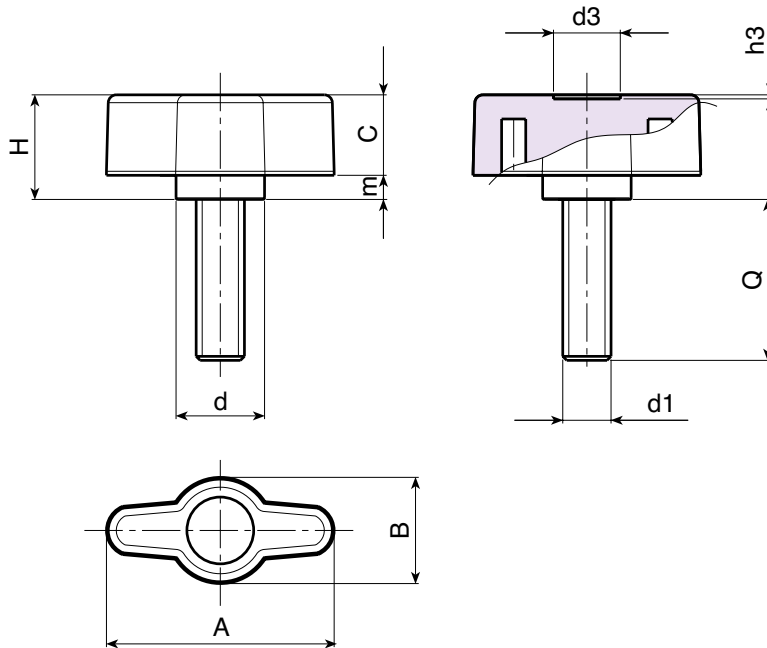

	Art.	A	B	H	m	c	d	d3	h3	LM	d1 6g	Q	g
	L74928.TM04X..01	28	13	13	3	10	11	8	0,5	75	M04	A.R.	-
	L74928.TM05X..01	28	13	13	3	10	11	8	0,5	75	M05	A.R.	-
	L74928.TM06X4001	28	13	13	3	10	11	8	0,5	75	M06	40	11

Enter the stud length choice in the two .. of the article code. Lengths by request with 250 pieces minimum quantity.

LM = Maximum mouldable length.

A.R. = By request.