

# R277

**NEW**



**\*\*non tradotto\*\***

**Materials:**

**Wheel body (1):**

**\*\*non tradotto\*\***

**Tread (2):**

**\*\*non tradotto\*\***

**Surface finish:**

Smooth.

**Colour:**

**\*\*non tradotto\*\***

**\*\*non tradotto\*\***

(3-4-5-6) Galvanised blue.

**Wheel rotation (4):**

A pair of steel ball bearings is inserted in the wheel hub to provide excellent rollability.

**Bracket (3):**

Extra-thick steel (DD13) fork.

**Rotating assembly (5):**

Steel rotating assembly with double ball race, assembled with steel screw grade 8.8 and rectangular swivel plate with four slotted mounting holes.

**Wheel fastening (6):**

Steel hex head screw, coupled with a self-locking steel nut.

**Special requests:**

- None.

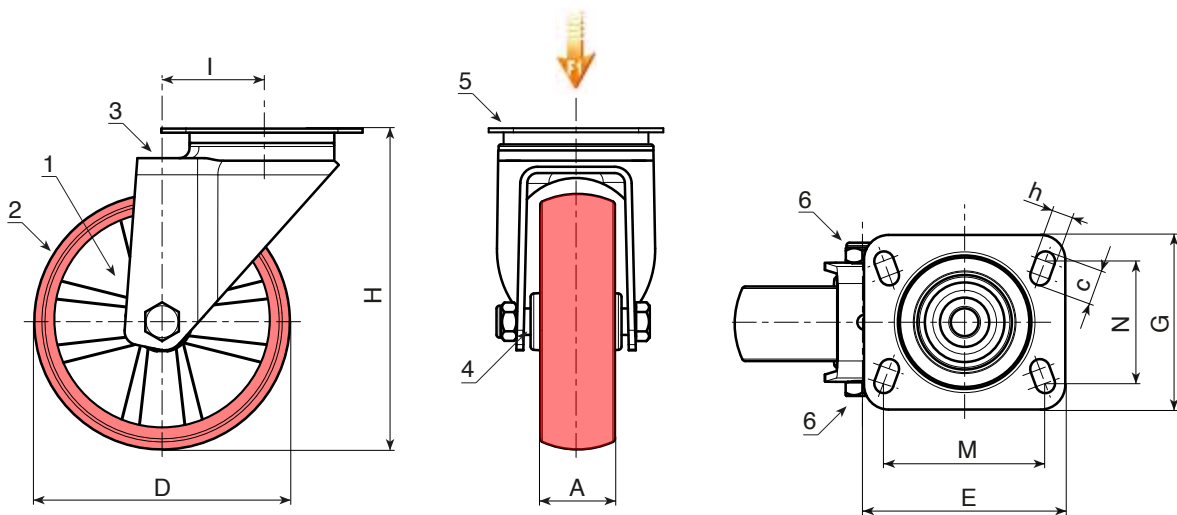

art.	D	A	H	I	E	G	M	N	c	h	g	F1 (Kg)
R277080.T25P080X060	80	25	108	32	100	80	80	60	12	9	-	150
R277100.T30P080X060	100	30	127	33	100	80	80	60	12	9	-	180
R277125.T30P080X060	125	30	155	39	100	80	80	60	12	9	-	180
R277150.T40P105X080	150	40	186	47	133	106	105	80	23	11	-	300
R277200.T50P105X080	200	50	240	56	132	110	105	80	23	12	-	300