

R279

NEW



****non tradotto****

Materials:

Wheel body (1):

****non tradotto****

Tread (2):

****non tradotto****

Surface finish:

Smooth.

Colour:

****non tradotto****

****non tradotto****

(3-4-5-6) Galvanised blue.

Wheel rotation (4):

A pair of steel ball bearings is inserted in the wheel hub to provide excellent rollability.

Bracket (3):

Extra-thick steel (DD13) fork, with mounting holes in the base.

Wheel fastening (6):

Steel hex head screw, coupled with a self-locking steel nut.

Special requests:

- None.

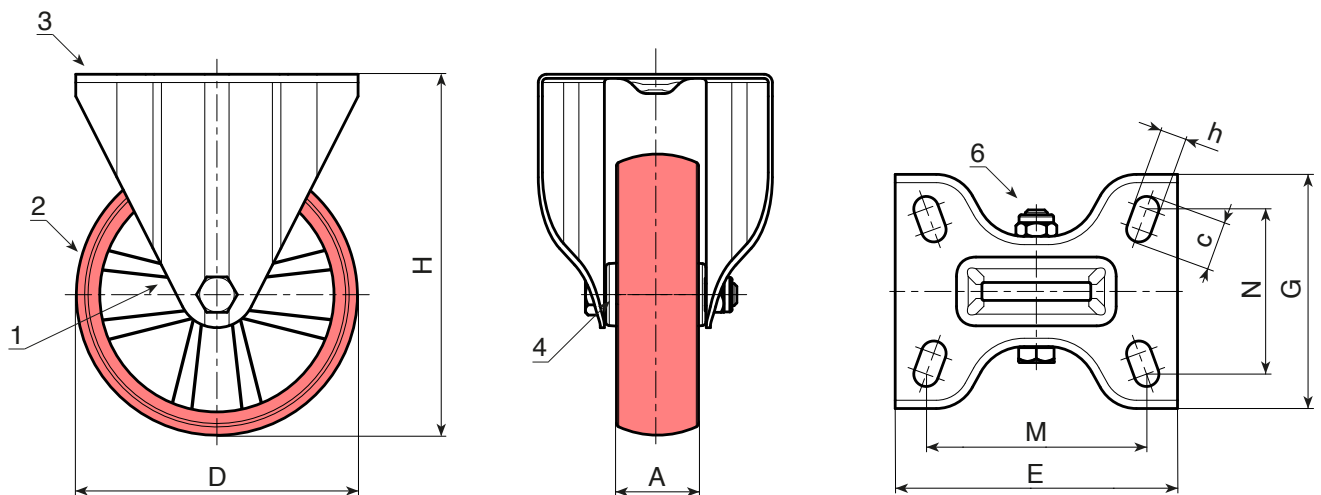

art.	D	A	H	E	G	M	N	c	h	g	F1 (Kg)
R279080.T25P080X060	80	25	108	100	84	80	60	12	9	-	150
R279100.T30P080X060	100	30	127	100	84	80	60	12	9	-	180
R279125.T30P080X060	125	30	155	100	84	80	60	12	9	-	180
R279150.T40P105X080	150	40	184	134	110	105	80	23	11	-	220
R279200.T50P105X080	200	50	240	135	110	105	80	23	11	-	300