

5-140 Window Seals

EPDM / NBR



Window seals are used to mount panes, windows, etc. in doors, casings and machine enclosures.

- They are made of EPDM. The pane is mounted by simply pressing it into the window seal.
- Additional tools are not required. The pane is inside or outside the enclosure and hence is well-suited for use under high pressure or vacuum conditions.
- Tolerances: see page 07.07.

Customized designs:

- If the cross-sections shown here are not suitable for your specific application, we can produce a customized profile to meet your needs.
- All standard window seals are available from stock.

Material:

- **Rubber quality:** EPDM or Perbunan (NBR), NBR is oil-resistant

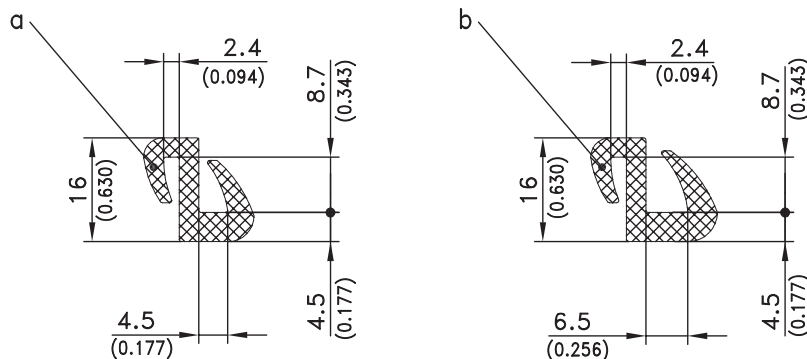
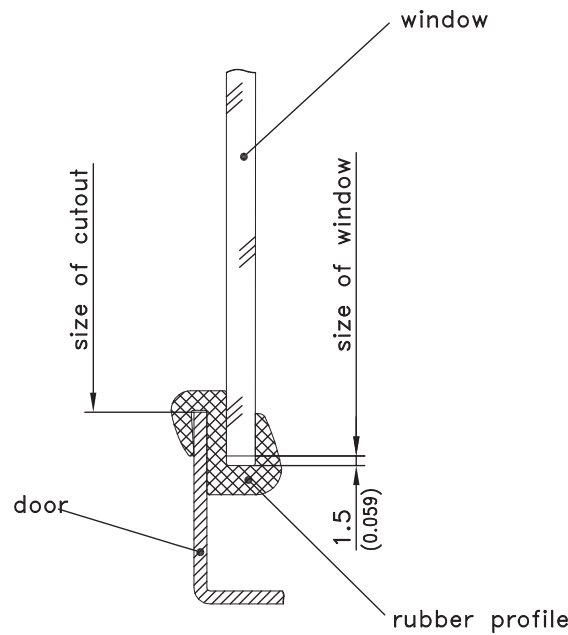
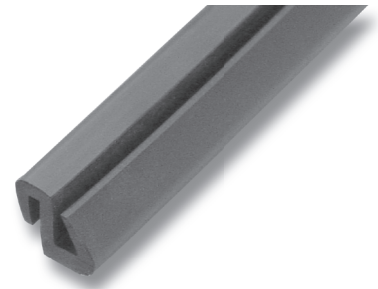

	color	Bending radius	packaging unit	Material	Part No.
a)	black	min 80mm	100m	rubber / EPDM	209-0401
	black	min 80mm	100m	NBR	209-0406
b)	black	min 80mm	100m	rubber / EPDM	209-0402
	black	min 80mm	100m	NBR	209-0407

Dimension sheet metal cutout is equivalent to dimension window - 14.5mm/0.571