

Articulated feet, sanitizable

(base in stainless steel)

Part. **107** \varnothing **75**

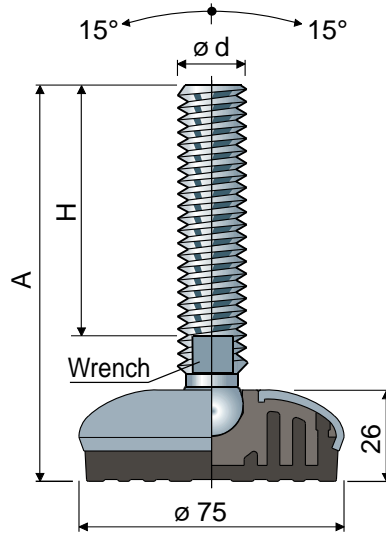

Spindle measures in mm				Spindle and base in stainless steel AISI 304	Max static load (N)
$\varnothing d$	A	H	Wrench		
M16	103	60	13	107 / 83524	19000
	133	90	13	107 / 83525	
	148	105	13	107 / 83526	
	168	125	13	107 / 83527	
	198	155	13	107 / 83528	
	208	165	13	107 / 83529	
	248	205	13	107 / 83530	
M20	132	86	17	107 / 83531	21000
	162	116	17	107 / 83532	
	187	141	17	107 / 83533	
	252	206	17	107 / 83534	
M24	142	96	19	107 / 83535	23000
	168	122	19	107 / 83536	
	198	152	19	107 / 83537	
	228	182	19	107 / 83538	
	346	300	19	107 / 83539	
M30	190	144	24	107 / 86221 NEW	25000

Spindle measures in mm				Spindle and base in stainless steel AISI 304	Max static load (N)
$\varnothing d$	A	H	Wrench		
5/8" -11 UNC	8,70"	7"	1/2"	107 / 83592	19000
3/4" -10 UNC	8,78"	7"	5/8"	107 / 83593	21000

Material: Internal part made of reinforced polyamide; external covering made of stainless steel AISI 304; anti-slip pad made of thermoplastic rubber 68 Shore black colour.

Box quantity: 8 pieces.

Features: Comoulded anti-slip pad allows a perfect adherence with steel base. Consequent absence of internal cavities makes foot extremely cleanable.

Washers UNI 6592-69 - Box quantity: 24 pieces.

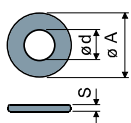

$\varnothing M$	M16	M20	M24	M30
Smm	3	3	4	4
$\varnothing A$ mm	30	37	44	56
Stainless steel codes	7291	7292	7294	7296

Nuts UNI 5588-65 - Box quantity: 24 pieces.

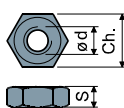

$\varnothing d$	M16	M20	M24	M30
Smm	13	16	19	24
Ch. mm	24	30	36	46
Stainless steel codes	7277	7278	7280	7282

On request

- Spindles with: Sunk hexagon head • second wrench seat head • hexagon wrench seat • threads with other pitches and lengths • stainless steel AISI 316.
- Anti-slip pads: White colour.
- Box quantity: Not standard.
- Assembling of: Nuts • washers.