

D454



PA6
+GF

UL94
HB



"EUROMODEL" 4 ARMS CONTROL HANDWHEEL

PROTECTED MODEL

Material:

Reinforced and stabilised polyamide.
Oils and greases resistant.

Surface:

Satin.

Colour:

Black (RAL 9011).

Central Cap:

Grey polyamide (RAL 7035 cod. 13).

Alternative Cap Colour:

Orange (RAL 2004 cod. 02)
Blue (RAL 5015 cod. 07)
Yellow (RAL 1021 cod. 10)
Red (RAL 3000 cod. 16)
Green (RAL 6024 cod. 17)
Black (RAL 9011 cod. 01)

Main Insert:

Zinc plated steel insert with smooth through-hole (H11 tolerance).

Hub:

Hollow underneath hub.

For fixing system, or execution of keyway or square holes, please refer to the technical notes attached to the catalogue.

SPECIAL REQUEST:

- It's possible to supply the inserts with d1 bore by customer design, on request and for quantities.
- It's possible to supply the inserts with threaded d1 bore, on request and for quantities.
- It's possible to supply the inserts in different material and treatment-finishes, on request and for quantities.

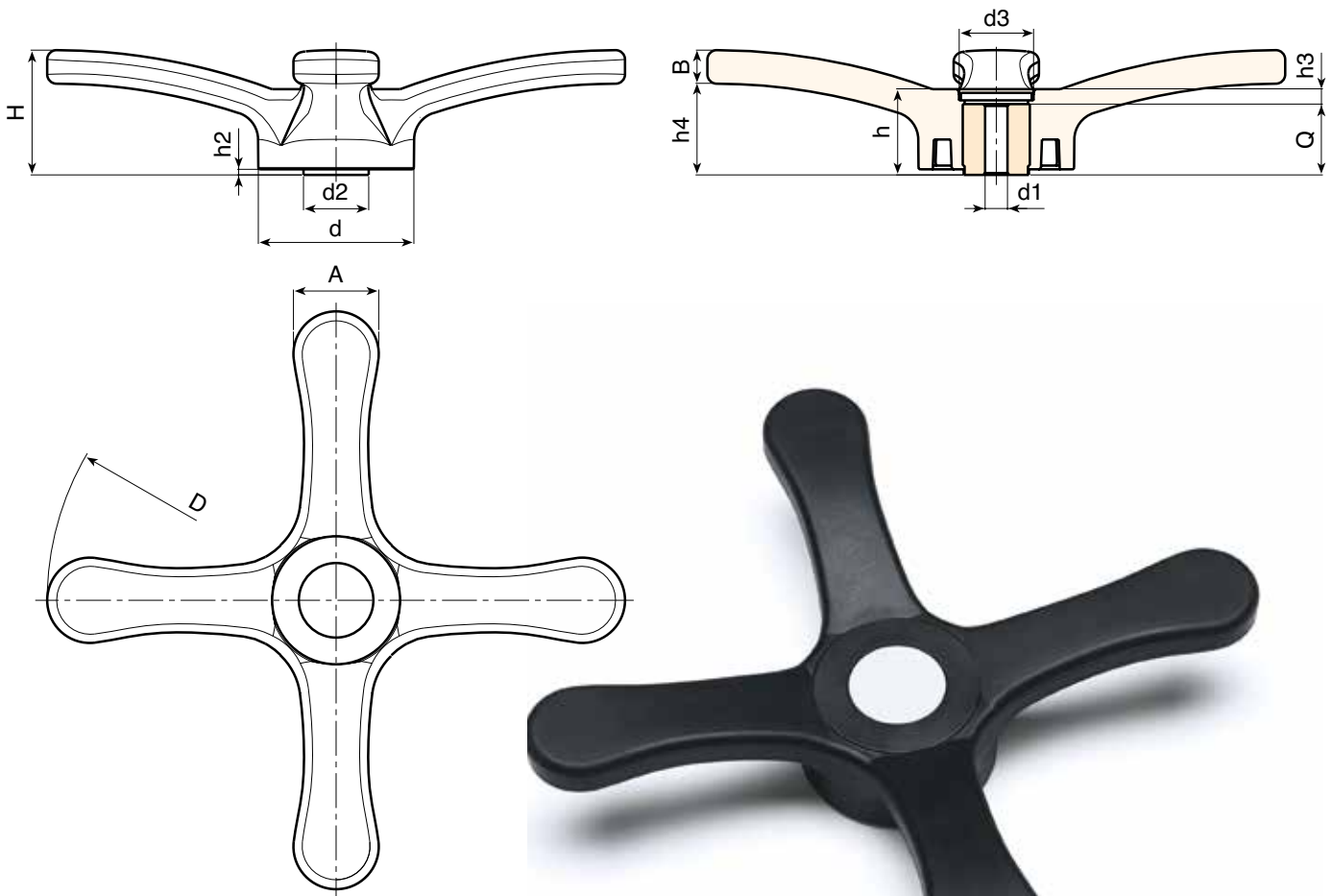

Version with zinc plated insert and H11 tolerance bore

Art.	D	H	h	d	d2	A	B	h2	h3	h4	d3	Dm	d1 H11	Q	Δg
D454310.TD0801P	308	66	45,5	83	35,5	45,5	20	3	7,5	46	34	26	8	38	900

Attention: bore d1 (H11 tolerance) could be produced by request, with 100 pieces minimum.

Dm = It's possible to increase the hole, by boring, until Dm (enlarge).

D - CONTROL HANDWHEELS

ver. DUK.10-0113



D - 14

Availability of stock in %

(☹) 90% (😊) 40% (☺) 5% (☹)

www.boteco.it - © All right reserved - BOTECA®
Any unauthorized reproduction is strictly forbidden