

F178CAT

+135°
-30°

PA6
+G.F.

UL94
HB

RoHS
COMPLIANT

6-LOBE SOLID HANDWHEEL WITH RETAINING CHAIN AND THREADED STUD

Materials:

Reinforced polyamide.
Resistant to oils and greases.

Surface finish:

Satin.

Colour:

Black (RAL 9011).

Inserts:

- (1) Galvanised steel threaded stud (thread tolerance 6g).
- (2) Galvanised steel turned ring nut, secured with threadlocker and with groove for retaining hook.

Chain:

Black acetal (POM) chain. Harmonic stainless steel (Aisi 302) joints, retaining ring and hub hook.

Special Requests:

- Upon request and for special quantities inserts can be supplied with customised lengths.
- Upon request the chain can be supplied with customised lengths.
- Upon request and for special quantities inserts can be supplied in different materials.
- Upon request and for special quantities available in the colours indicated in the chart (attention: reduced range) [page 805].

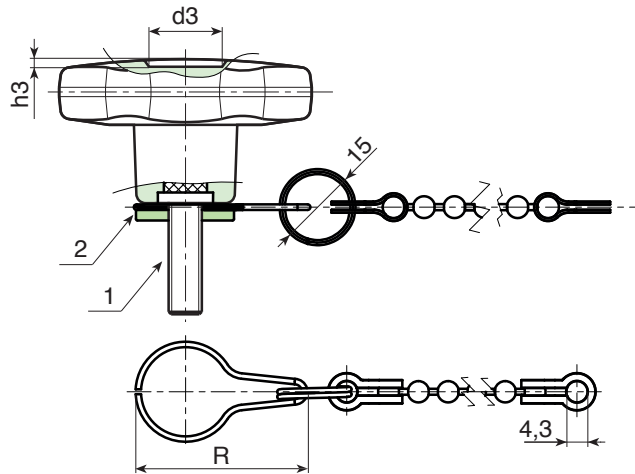
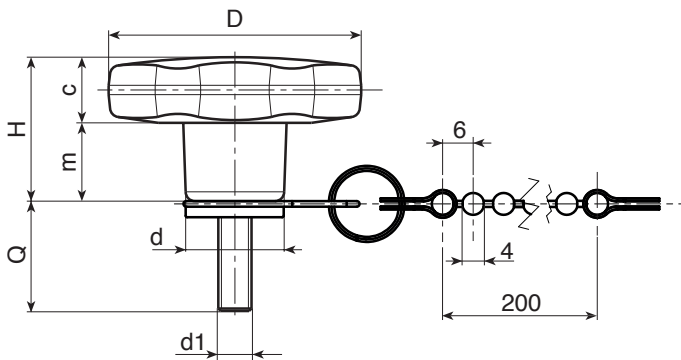

Art.	D	H	d	R	c	m	d3	h3	LM	d1 _{6g}	Q	g
F17830.TM05X..01CAT	30	22	15	32	11	11	9	1.5	80	M5	10-16-20-30-40	13-14-15-16-17
F17830.TM06X..01CAT	30	22	15	32	11	11	9	1.5	80	M6	10-16-20-25-30-40	18-19-20-20,5-21-22
F17830.TM08X..01CAT	30	22	15	32	11	11	9	1.5	80	M8	16-20-30-40	22-24-28-31
F17830.TM10X..01CAT	30	22	15	32	11	11	9	1.5	80	M10	20-30-40	31-36-42
F17840.TM06X..01CAT	40	24.5	17	33	12	12.5	12	1	130	M6	16-20-30-40	28-28-30-31
F17840.TM08X..01CAT	40	24.5	17	33	12	12.5	12	1	130	M8	16-20-25-30-35-40-45-50	31-33-34-36-37-39-41-42
F17840.TM10X..01CAT	40	24.5	17	33	12	12.5	12	1	130	M10	20-30-40-50	40-44-48-52
F17850.TM08X..01CAT	50	29	20	35	14	15	14.5	1.5	130	M8	15-20-30-40	51-52-55-58
F17850.TM10X..01CAT	50	29	20	35	14	15	14.5	1.5	130	M10	20-25-30-40-50	58-60-63-64-67
F17850.TM12X..01CAT	50	29	20	35	14	15	14.5	1.5	130	M12	20-30-40-50	66-70-75-80
F17860.TM08X..01CAT	60	34	24	38	16	18	18	1.5	130	M8	30-40	74-77
F17860.TM10X..01CAT	60	34	24	38	16	18	18	1.5	130	M10	20-30-40-50	77-83-88-91
F17860.TM12X..01CAT	60	34	24	38	16	18	18	1.5	130	M12	20-30-40-50	98-105-112-119

Enter the selected stud length in place of the two dots . . in the item code. Customised stud length available for a minimum of 150 pieces.

