

ART. F764-F664

3-LOBE HANDWHEEL WITH THREADED STUD

MATERIAL:
Reinforced polyamide.
Oils and greases resistant.

SURFACE:
Satin.

COLOUR:
Black (RAL 9011).

MAIN INSERT:
Zinc plated steel threaded stud.

HUB:
F661 Version - solid.
F761 Version - hollow underneath.

SPECIAL REQUESTS:

- It is possible to supply the inserts with different lengths, on request and for quantities.
- It is possible to supply the inserts in different materials, on request and for quantities.
- It is possible to supply colours as shown in the table at page 23, on request and for quantities.

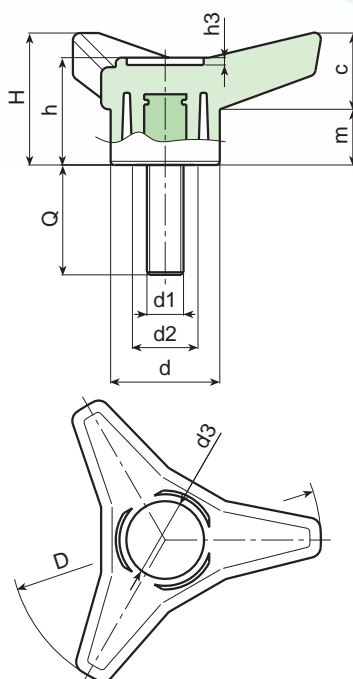

Art.		D	H	h	d	c	m	d2	d3	h3	d1	Q	LM	Weight (gr)
hollow hub	solid hub													
-	F664 -45 M06	45	21	18	16	11	10	-/-	11	1	M06	20-30	60	14-17
-	F664 -45 M08	45	21	18	16	11	10	-/-	11	1	M08	20-30	60	19-22
-	F664 -45 M10	45	21	18	16	11	10	-/-	11	1	M10	30	60	23
-	F664 -65 M08	65	28	23,5	22	16,5	11,5	-/-	15,5	1,5	M08	20-30	80	36-39
-	F664 -65 M10	65	28	23,5	22	16,5	11,5	-/-	15,5	1,5	M10	20-30	80	43-47
-	F664 -65 M12	65	28	23,5	22	16,5	11,5	-/-	15,5	1,5	M12	40	80	67
F764	F664 -85 M08	85	37	30,5	30	21	16	18/-	21	2	M08	20-30-40	60	61-65-69
F764	F664 -85 M10	85	37	30,5	30	21	16	18/-	21	2	M10	20-30-40	60	66-74-80
F764	F664 -85 M12	85	37	30,5	30	21	16	18/-	21	2	M12	20-40	60	83-94
F764	F664 -105 M10	105	46	37,5	35	26	19	20/-	25	2	M10	20-30-40	80	113-116-122
F764	F664 -105 M12	105	46	37,5	35	26	19	20/-	25	2	M12	30-50	80	121-136
F764	F664 -105 M14	105	46	37,5	35	26	19	20/-	25	2	M14	30	80	134
F764	F664 -125 M12	125	54	44	42,5	31	23	26/-	28,5	2	M12	30-50	100	200-214
F764	F664 -125 M14	125	54	44	42,5	31	23	26/-	28,5	2	M14	30	100	219
-	F664 -125 M16	125	54	44	42,5	31	23	-/-	28,5	2	M16	30	100	232
-	F664 -125 M18	125	54	44	42,5	31	23	-/-	28,5	2	M18	30	100	256

LM = Maximum mouldable length



BOTECA