

"EUROMODEL" HANDLE WITH THREADED STUD

M240



Material:

Reinforced polyamide. Oils and greases resistant.

Surface:

Satin.

Colour:

Black (RAL 9011).

Central Cap:

Grey polyamide (RAL 7035 cod. 13).

Alternative Cap Colour:

- Orange (RAL 2004 cod. 02)
- Blue (RAL 5015 cod. 07)
- Yellow (RAL 1021 cod. 10)
- Red (RAL 3000 cod. 16)
- Green (RAL 6024 cod. 17)
- Black (RAL 9011 cod. 01)

Main Insert:

Zinc plated steel threaded stud (tolerance 6g).

SPECIAL REQUEST:

- It is possible to supply inserts in different lengths or by special design, on request and for quantities.
- It is possible to supply inserts in different materials, on request and for quantities.
- It is possible to supply colours as shown in the table at pag. M-27, on request and for quantities.

Studs lengths already setup on the tool:

For all threaded size:

10-15-20-25-30-35-40-45-50-55-60-65-70-75-80

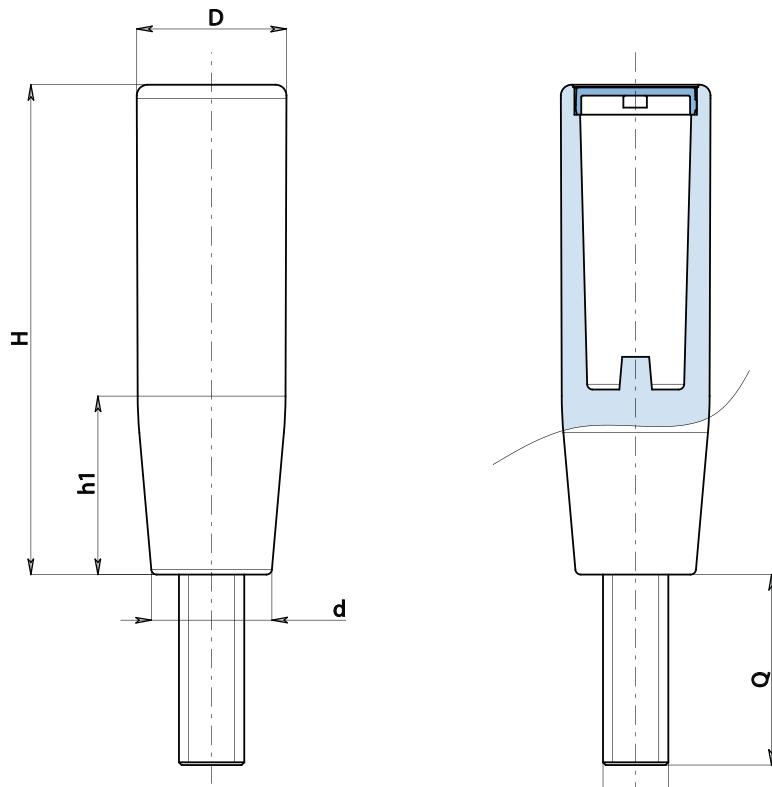

art.	H	D	d	h1	LM	d1 6g	Q	Δ g
M24090.TM08X..0113	89,5	27	22	32	80	M08	10-20-30	65-68-71
M24090.TM10X..0113	89,5	27	22	32	80	M10	10-20-30	70-75-80
M24090.TM12X..0113	89,5	27	22	32	80	M12	20-30-40	83-90-97

Enter the stud length choice in the two .. of the article code. Lengths by request with 100 pieces minimum quantity.

LM = Maximum mouldable length.

Availability of stock in %

(☺) 90% (☹) 40% (⊖) 5%

BOTECO® - © All right reserved - www.boteco.it
Any unauthorized reproduction is strictly forbidden



M - TAPERED AND REVOLVING HANDLES