

P830

NEW

+135°
-30°

PA6
+G.F.

UL94
HB

RoHS
COMPLIANT

MOUNTING FOOT WITH BALL JOINT (R.24), HEXAGONAL BASE AND THREADED HOLE

Materials:

Reinforced polyamide.
Resistant to oils and greases.

Surface finish:

Satin.

Colour:

Black (RAL 9011).

Inserts:

P830:
Galvanised steel ball joint with threaded hole (ball R.24) with hexagonal base (thread tolerance 6H).

P830CIN:
Stainless steel (Aisi 303) ball joint with threaded hole (ball R.24) with hexagonal base (thread tolerance 6H).

Special requests:

- Upon request and for special quantities the foot can be supplied in Orange (RAL 2004).

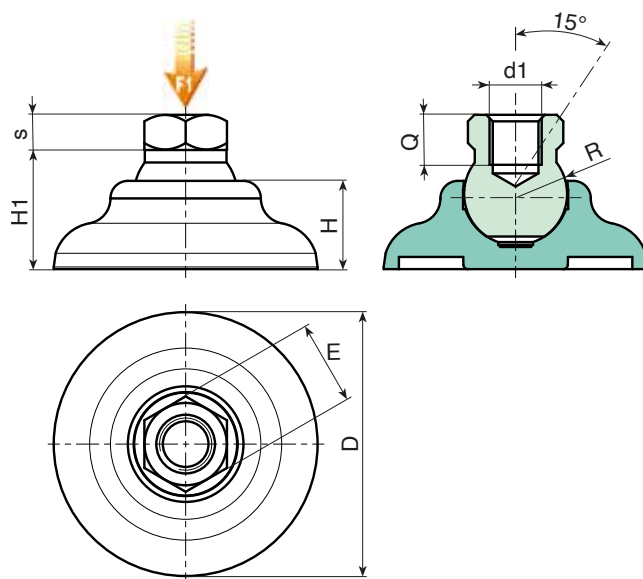

Version P830: with galvanised steel insert

🛒	Art.	D	H	Ht	E	s	R	d1 _{6H}	Q	g	F1 (kN)
●	P83060.TM1201	60	20	27,5	19	8	24	M12	11,5	--	17
●	P83060.TM1601	60	20	27,5	19	8	24	M16	11,5	--	17

Attention: The expressed load limit F1 is lower than the break load by 30% and is intended as static.

INOX

Version P830CIN: with stainless steel insert (Aisi 303)

🛒	Art.	D	H	Ht	E	s	R	d1 _{6H}	Q	g	F1 (kN)
●	P83060.TM1201CIN	60	20	27,5	19	8	24	M12	11,5	--	17
●	P83060.TM1601CIN	60	20	27,5	19	8	24	M16	11,5	--	17

Attention: The expressed load limit F1 is lower than the break load by 30% and is intended as static.

