

R201

NEW



POLYAMIDE / POLYURETHANE WHEEL WITH ROUND STEEL SWIVEL SUPPORT AND SMOOTH THROUGH HOLE

Materials:

Wheel body (1):

Polyamide. Resistant to oils and greases.

Tread (2):

Injected polyurethane. Hardness 60 ± 5 Shore D.

Surface finish:

Smooth.

Colour:

(1) Natural white.

(2) Red (Ral 3013).

(3-4-5-6) Galvanised blue.

Wheel rotation (4):

The hole for the pivot pin is formed by plastic moulding. A galvanised steel tube is positioned between the stud and the hole for protection.

Bracket (3):

Steel fork (DD13).

Rotating assembly (5):

Steel rotating assembly with double ball race and smooth fixing hole, (hole tolerance H7).

Wheel fastening (6):

Steel hex head screw, coupled with a steel nut.

Special requests:

- Upon request and for a minimum of 20 pieces, the wheel can be supplied with a needle roller cage, (replace code no. R201 with code no. R231).

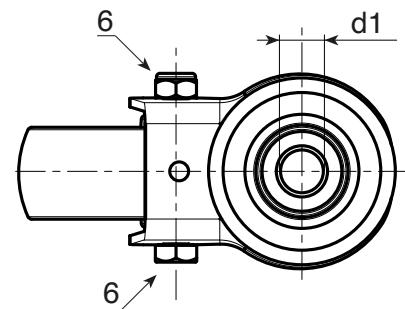
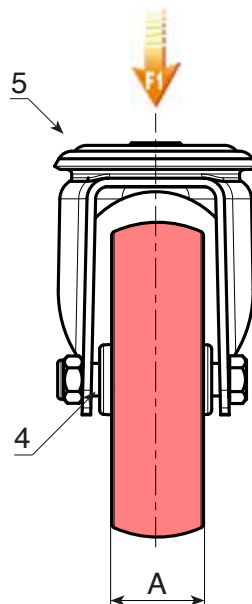
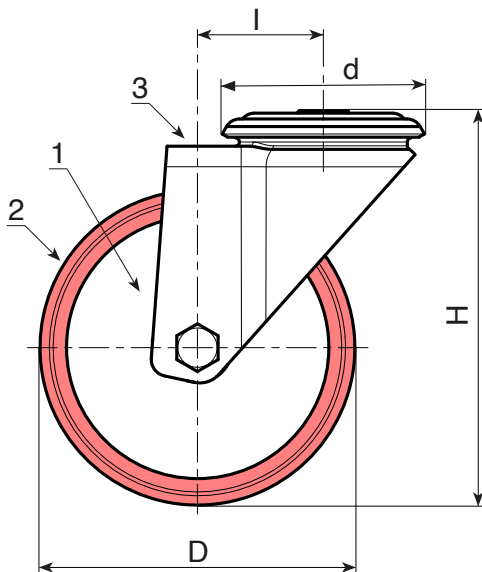

	art.	D	A	H	I	d	d1H7	g	F1 (Kg)
●	R201080.T30D12	80	30	108	32	64	12	486	100
●	R201100.T30D12	100	30	127	32	64	12	1170	130
●	R201125.T35D12	125	35	155	32	64	12	772	130
●	R201150.T40D12	150	40	184	35	65	12	-	140
●	R201200.T50D16	200	50	240	48	95	16	1934	270

R201CIN NEW



POLYAMIDE / POLYURETHANE WHEEL WITH ROUND STAINLESS STEEL SWIVEL SUPPORT AND SMOOTH THROUGH HOLE

INOX

Materials:

Wheel body (1):

Polyamide. Resistant to oils and greases.

Tread (2):

Injected polyurethane. Hardness 60 ± 5 Shore D.

Surface finish:

Smooth.

Colour:

(1) Natural white.

(2) Red (Ral 3013).

(3-4-5-6) Natural stainless steel.

Wheel rotation (4):

The hole for the pivot pin is formed by plastic moulding. A stainless steel (Aisi 304) tube is positioned between the stud and the hole for protection.

Bracket (3):

Stainless steel (Aisi 304) fork.

Rotating assembly (5):

Stainless steel (Aisi 304) rotating assembly with double stainless steel (Aisi 420) ball race and smooth fixing hole, (hole tolerance H7).

Wheel fastening (6):

Stainless steel (Aisi 304) hex head bolt, coupled with a stainless steel (Aisi 304) nut.

Special requests:

- Upon request and for a minimum of 20 pieces, the wheel can be supplied with a needle roller cage, (replace code no. R201CIN with code no. R231CIN).

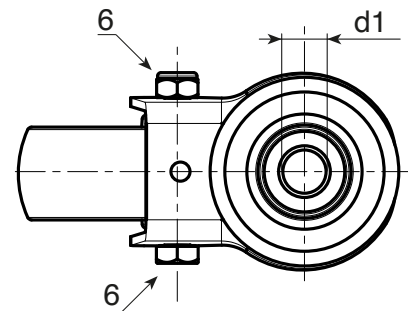
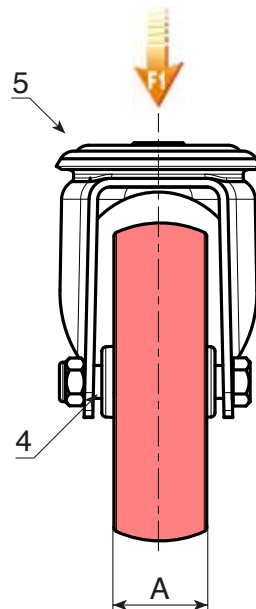
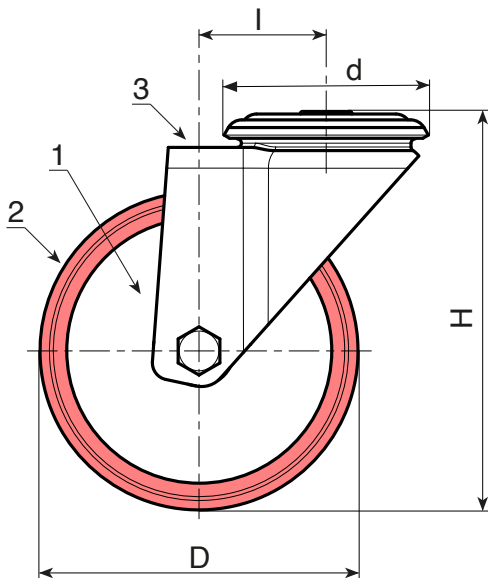

INOX

art.	D	A	H	l	d	d1H7	g	F1 (Kg)
R201080.T30D12CIN	80	30	108	32	64	12	486	100
R201100.T30D12CIN	100	30	127	32	64	12	544	130
R201125.T35D12CIN	125	35	155	32	64	12	654	130
R201150.T40D12CIN	150	40	184	35	65	12	-	140
R201200.T50D16CIN	200	50	240	48	95	16	-	300