

R407

NEW

max
3 Km/h

+50°
- 5°

PP

TPE

UL94
HB

RoHS
COMPLIANT

POLYPROPYLENE / RUBBER WHEEL WITH RECTANGULAR SWIVEL STEEL PLATE

Materials:

Wheel body:

Polypropylene.

Tread:

Synthetic thermoplastic rubber. Hardness 93 ± 3 Shore A.

Surface finish:

Smooth.

Colour:

(1) Black (RAL 9011).

(2) Light grey.

(3-4-5-6-7) Galvanised blue.

Wheel rotation (4):

The hole for the pivot pin is formed by plastic moulding. A galvanised steel tube is positioned between the stud and the hole for protection.

Bracket (3):

Steel fork (DD13).

Rotating assembly (5):

Steel rotating assembly with double ball race, and rectangular swivel plate with four slotted mounting holes.

Wheel fastening (6):

Steel hex head screw, coupled with a steel nut.

Thread guards (6):

Sheared steel thread guard disk fixed on both sides.

Special requests:

- None.

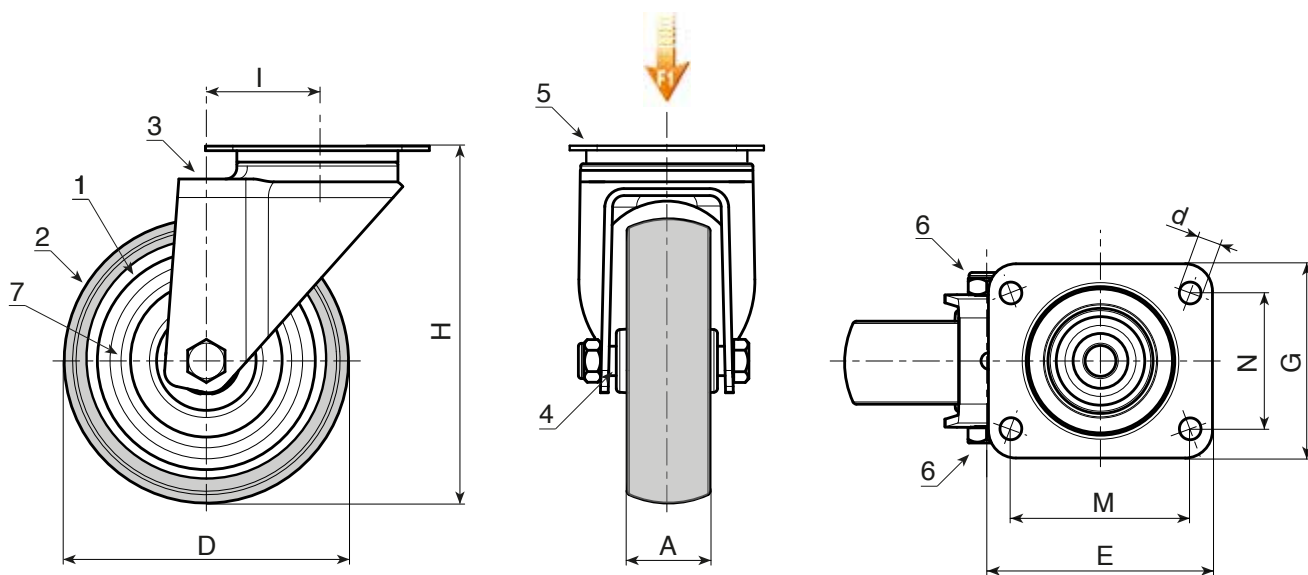

	art.	D	A	H	I	E	G	M	N	d	g	F1 (Kg)
●	R407050.T18P045X045	50	18	70	26	60	60	45	45	6,5	-	40
●	R407063.T22P045X045	63	22	90	26	60	60	45	45	6,5	-	60
●	R407080.T22P045X045	80	22	109	25	60	60	45	45	6,5	-	60
●	R407100.T27P060X050	100	27	134	36	76	70	60	50	8,3	-	80
●	R407125.T27P060X050	125	27	159	35	76	70	60	50	8,3	-	80