

W464



KNURLED METAL HANDWHEEL WITH THREADED STUD

Materials:

W464:

Steel with strength class 5.8.

W464CIN:

Stainless steel (Aisi 303).

Surface finish:

Turned with low roughness.

Colour:

W464:

Nickel plated (galvanic treatment).

W464 CIN:

Natural.

Alternative finishes:

Black-oxide treatment:

(replace the final letter of the code (H) with letter B (W46429.SM08X..B).

Galvanising:

(replace the final letter of the code (H) with letter Z (W46429.SM08X..Z).

Stud:

Threaded stud machined from solid metal (thread tolerance 6g).

Special requests:

- Upon request and for special quantities inserts can be supplied with customised lengths.

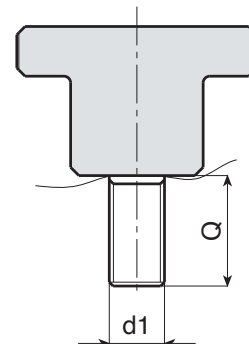
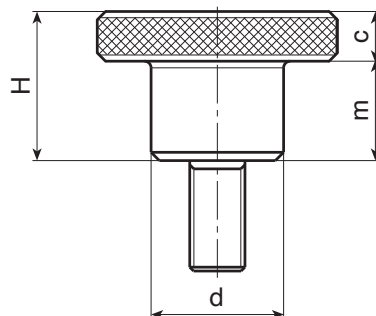
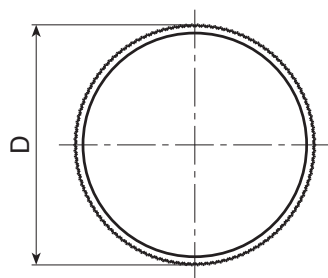

Version W464 - nickel-plated steel

Art.	d	D	H	m	c	Q MAX	d1 _{6g}	Q	g
W46411.SM03X16H	6	11	8	5	3	16	M3	16	5
W46415.SM04X10H	8	15	10	6	4	20	M4	10	7.8
W46419.SM05X..H	10	19	12	8	4	20	M5	16-30	15,6-17
W46423.SM06X..H	12	23	15	10	5	30	M6	16-35	27,5-30,5
W46429.SM08X..H	16	29	18	12	6	40	M8	16-30	55-59
W46435.SM10X25H	20	35	23	15	8	40	M10	25	109.5

Enter the selected stud length in place of the two dots . . in the item code.

A.R. = Customised stud length available for a minimum of 100 pieces.

Qmax = maximum turning length.

Version W464 CIN - stainless steel (Aisi 303)

Art.	d	D	H	m	c	Q MAX	d1 _{6g}	Q	g
W46411.IM03X..CIN	6	11	8	5	3	16	M3	A.R.	-
W46415.IM04X..CIN	8	15	10	6	4	20	M4	A.R.	-
W46419.IM05X..CIN	10	19	12	8	4	20	M5	A.R.	-
W46423.IM06X35CIN	12	23	15	10	5	30	M6	35	30.5
W46429.IM08X..CIN	16	29	18	12	6	40	M8	A.R.	-
W46435.IM10X..CIN	20	35	23	15	8	40	M10	A.R.	-

Enter the selected stud length in place of the two dots . . in the item code.

A.R. = Customised stud length available for a minimum of 100 pieces.

Qmax = maximum turning length.

INOX

