

W722CIN - W723CIN



KNOB WITH LOCKING FULL STAINLESS STEEL INDEXING PLUNGER - WITH OR WITHOUT NUT

Materials:

- (1) Stainless steel plunger pin (Aisi 303).
- (2) Threaded stainless steel hexagon ring nut (Aisi 303).
- (3) Stainless steel spring (Aisi 301).
- (4) Turned stainless steel lobed knob (Aisi 303).
- (5) Stainless steel fixing screw (Aisi 304).
- (6) Threaded stainless steel lock nut (Aisi 304) (UNI 5589) (only for version W723CIN).

Surface finish:

Natural.

Colour:

Natural.

ATTENTION:

- > We recommend an H7 tolerance for the plunger stem bore.
- > Nut supplied assembled (only for version W723CIN).

Special Requests:

- Upon request and for special quantities the plunger can be supplied completely disassembled.
- On request the nut can be supplied disassembled.

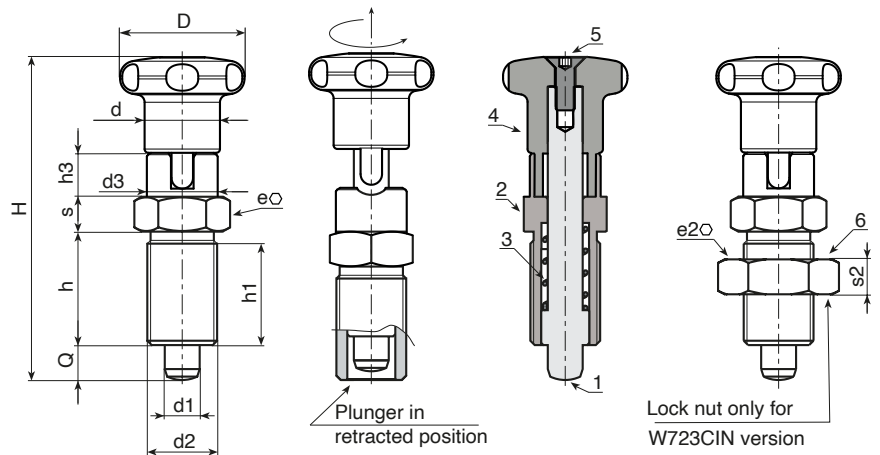

Version W722 CIN - without nut

🛒	Art.	D	H	h	h1	h3	d2	d	d3	e	s	d1 -0,02 -0,04	Q	📦
●	W722.I0501CIN	22	52	17	15	6.5	M10x1	12	12	12	5	5	5	-
●	W722.I0601CIN	27	61	20	18	7.5	M12x1,5	14	14	14	6	6	6	-
●	W722.I0801CIN	32	77	26	24	9.5	M16x1,5	19	19	19	8	8	8	-
●	W722.I1001CIN	33	90	33	31	11.5	M20x1,5	19	19	22	10	10	10	210

Version W723 CIN - with nut

🛒	Art.	D	H	h	h1	h3	d3	d2	d	e	s	e2	s2	d1 -0,02 -0,04	Q	📦
●	W723.I0501CIN	22	52	17	15	6.5	12	M10x1	12	12	5	17	6	5	5	-
●	W723.I0601CIN	27	61	20	18	7.5	14	M12x1,5	14	14	6	19	7	6	6	-
●	W723.I0801CIN	32	77	26	24	9.5	19	M16x1,5	19	19	8	24	8	8	8	-
●	W723.I1001CIN	33	90	33	31	11.5	19	M20x1,5	20	22	10	30	9	10	10	240