

WELDABLE BLACK-OXIDE TREATED STEEL KNOB STYLE INDEXING PLUNGER WITH PIN

W806



Material:

(4) Reinforced polyamide scallop knob.

Inserts:

(3) Zinc plated steel spring.

(2) Bored unthreaded, welding quality steel body.

(1) Hardened high resistance steel plunger pin.

ATTENTION: The manufacturer recommends making the lodging hole for the plunger pin with a tolerance H7.

Surface:

(4) Black satin finish (RAL 9011).

(1.2) Black-oxide finish.

Packs containing 10 pieces.

SPECIAL REQUESTS:

- On request and for special quantities the knob is available in a choice of colours as indicated in the table on page 31.

ATTENTION:

TO AVOID PROBLEMS WHEN WELDING THE IRON BODY TO THE MACHINERY, THE PLASTIC KNOB IS SUPPLIED SEPARATELY. SCREW THE KNOB ON ONCE THE PART HAS COOLED.

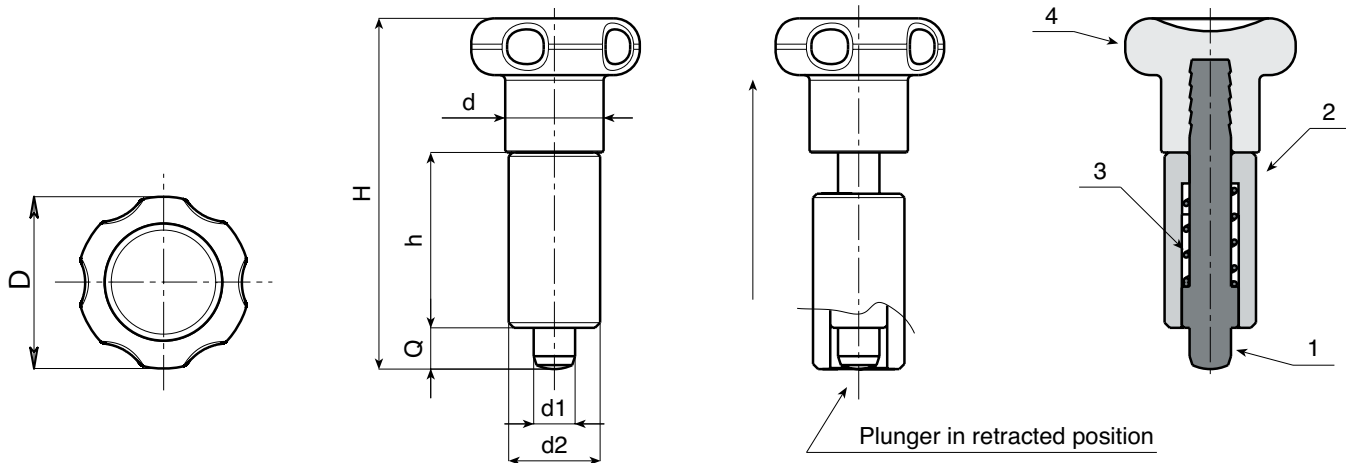

Art.	D	H	h	d2	d	d1 $-0,02$	Q	g
W806.Q0501	22	45	22	12	12	5	5	23
W806.Q0601	27	54	26	14	14	6	6	40
W806.Q0801	33	68	34	18	19	8	8	84

Presumable presence in the stock in %

(☺) 90% (☹) 40% (⊖) 5% (⊕)

BOTECO® - © All right reserved - www.boteco.it

Any unauthorized reproduction is strictly forbidden



W-S - 3

W - S
PLUNGERS

ver. W-SUK.01-0613