



6-125SL Slam Latch SNAP-LINE

PICCOLO, for flush doors, tool-less installation

Benefits:

- ▶ Just slightly protruding slam latch.
- ▶ Field of application: latching small doors or panels.
- ▶ To release: after unlocking, just push the upper, clearly marked part of the handle. The lower part then can be pulled-out and this disengages the spring loaded slam-bolt.
- ▶ The spring-loaded slam bolt has a free-stroke, allowing slamming of closed and locked handles.
- ▶ Only available with key number 23211.
- ▶ **Installation:** Enter slam-side into the cutout first and then snap-in the unit.

Material:

- ▶ **Housing, handle and slam-bolt:** PA, black
- ▶ **Cam:** steel, zinc plated
- ▶ **Pin:** steel, zinc plated
- ▶ **Snap wedges:** sintered steel



Slam-latch with cylinder without key

Part Number	Lockable	Cutout	Installation type	Clamping range
482-9001.00-00015	Yes	PrA	tool-less	1,2 - 1,7 mm
482-9001.00-00020	Yes	PrA	tool-less	1,7 - 2,2 mm
482-9001.00-00025	Yes	PrA	tool-less	2,2 - 2,7 mm

Slam-latch with locking cylinder + 2 keys

Part Number	Lockable	Cutout	Installation type	Clamping range
482-9002.00-00015	Yes	PrA	tool-less	1,2 - 1,7 mm
482-9002.00-00020	Yes	PrA	tool-less	1,7 - 2,2 mm
482-9002.00-00025	Yes	PrA	tool-less	2,2 - 2,7 mm

Slam-latch without cylinder (blind plug)

Part Number	Lockable	Cutout	Installation type	Clamping range
482-9003.00-00015	No	PrA	tool-less	1,2 - 1,7 mm
482-9003.00-00020	No	PrA	tool-less	1,7 - 2,2 mm
482-9003.00-00025	No	PrA	tool-less	2,2 - 2,7 mm



Additional Information:

482-9001.00-00015, 482-9001.00-00020,
482-9001.00-00025 Without keys!

482-9002.00-00015, 482-9002.00-00020,
482-9002.00-00025 2 keys and ring!

Complementary Products:

6-125SL

Key

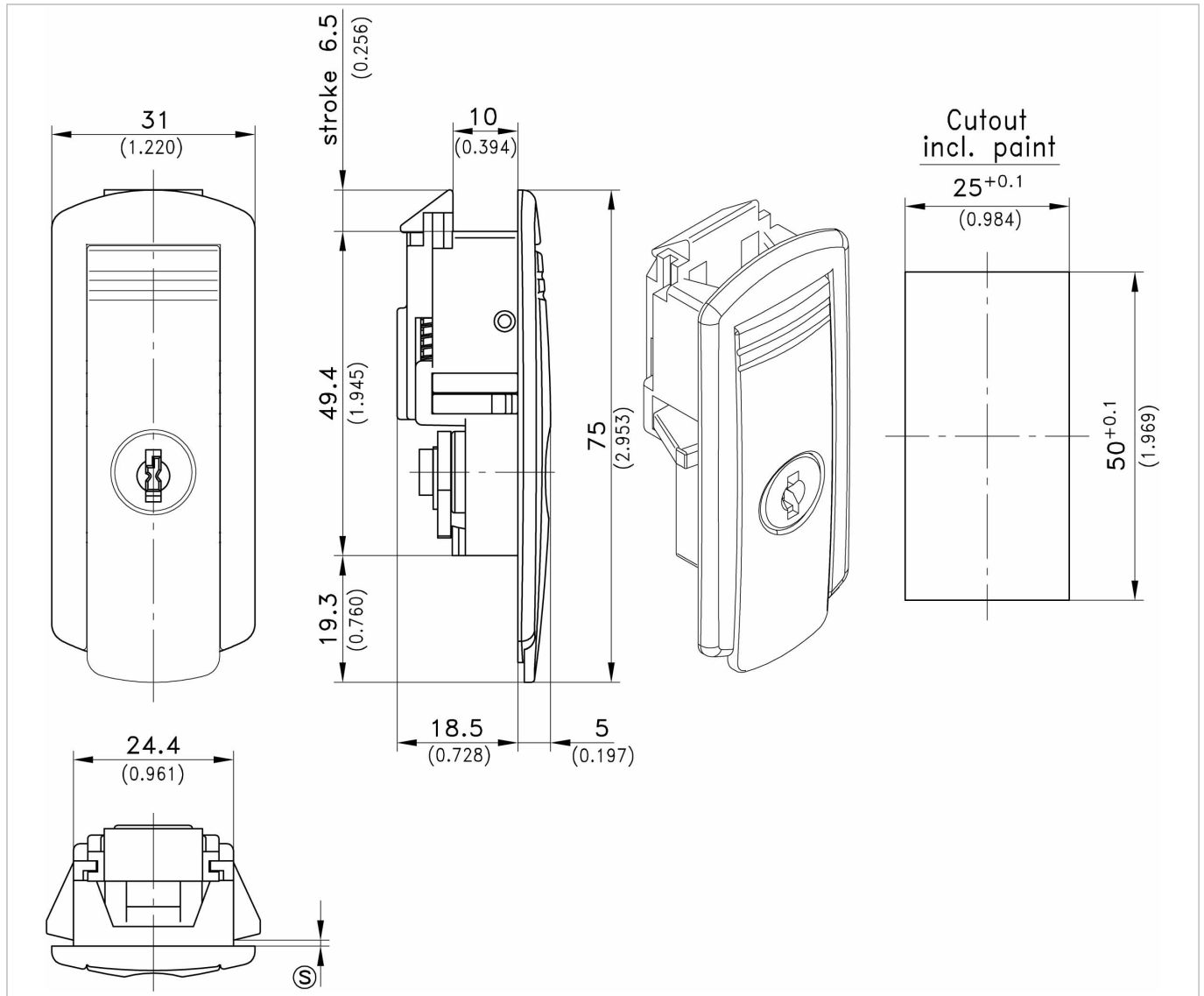

3-010 Cutout

for rod latch system

The Rod Latch system can be supplied for different cutouts.

- All designs conform to international standards for switchgear cabinets and are based on multiples of 25mm(0.984).
- Please refer to the relevant pages of the catalog for more information.

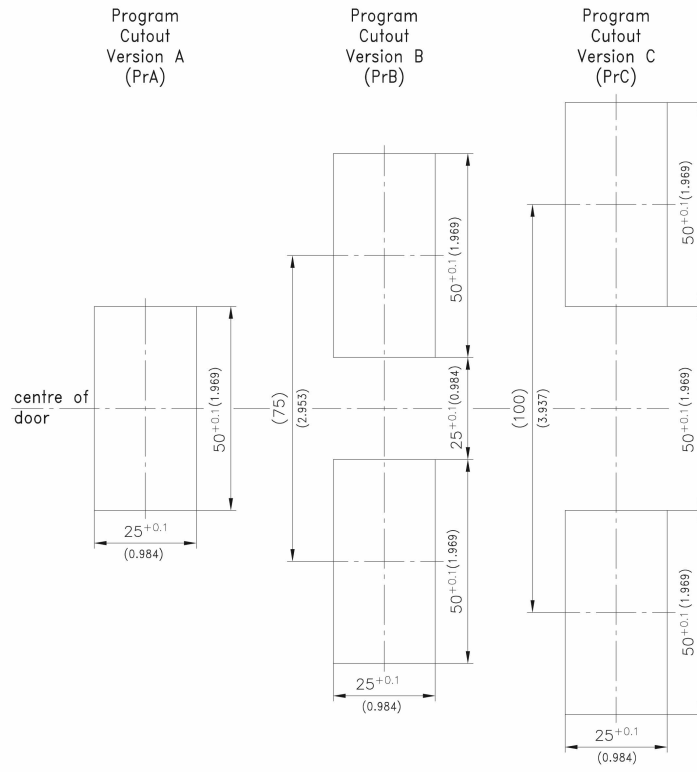

DIRAK GmbH Königsfelder Str. 1 58256 Ennepetal
 Tel.: 02333.837-0 Fax: 02333.837-100 www.dirak.com

06.02.2012
 © copyright by DIRAK / Germany

04.05