

Adjustable feet, sanitizable

(base in stainless steel)

Part. **126** \varnothing **150**

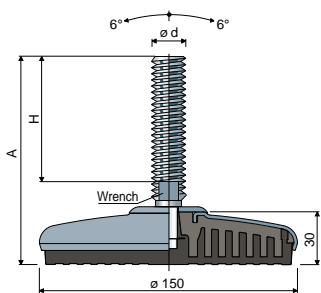

Type 1						
Spindle measures in mm						
$\varnothing d$	A	H	Wrench	Black	White	Max static load (N)
				Anti-slip pad Code	Anti-slip pad Code	
M20	157	107	17	126 / 86037	126 / 86042	40000
	185	135	17	126 / 86038	126 / 86043	
	207	157	17	126 / 86039	126 / 86044	
	240	190	17	126 / 86040	126 / 86045	
	288	238	17	126 / 86041	126 / 86046	
M24	145	90	19	126 / 86052	126 / 86056	40000
	182	127	19	126 / 86053	126 / 86057	
	217	162	19	126 / 86054	126 / 86058	
	257	202	19	126 / 86055	126 / 86059	
M30	172	125	24	126 / 86060	126 / 86062	40000
	232	185	24	126 / 86061	126 / 86063	

Material: Internal part made of reinforced polyamide; external covering made of stainless steel AISI 304; anti-slip pad made of thermoplastic rubber 68 Shore black or white colour.
Box quantity: 8 pieces.

Features: Comoulded anti-slip pad allows a perfect adherence with steel base. Consequent absence of internal cavities makes foot extremely cleanable. The threaded insert guarantees the protection of the spindle thread.

Washers UNI 6592-69 - Box quantity: 24 pieces.

$\varnothing M$	M20	M24	M30
Smm	3	4	4
$\varnothing A$ mm	37	44	56
Zinc plated steel codes	7290	7293	7295
Stainless steel codes	7292	7294	7296

Nuts UNI 5588-65 - Box quantity: 24 pieces.

$\varnothing d$	M20	M24	M30
Smm	16	19	24
Ch. mm	30	36	46
Zinc plated steel codes	7276	7279	7281
Stainless steel codes	7278	7280	7282

On request

- Spindles with: Sunk hexagon head • second wrench seat head • hexagon wrench seat • threads with other pitches and lengths • stainless steel AISI 316.
- Box quantity: Not standard.
- Assembling of: Nuts • washers.

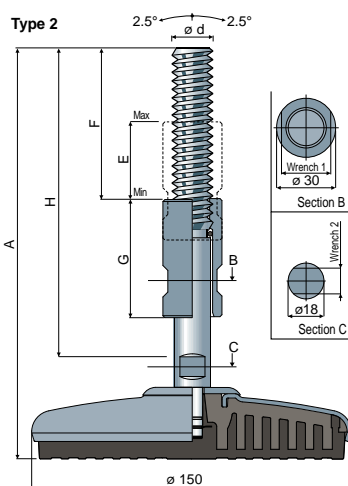

Type 2										
Spindle measures in mm										
$\varnothing d$	A	H	F	E	G	Wrench 1	Wrench 2	Black	White	Max static load (N)
								Anti-slip pad Code	Anti-slip pad Code	
M20	204	159	73	39	60	25	13	126 / 86047	126 / 86049	40000
	264	220	100	78	100	25	13	126 / 86048	126 / 86050	